















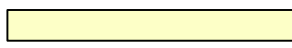

LEGEND

| | | |
|----------------|---|--|
| Drainage |  Pit |  Pit/Lintel |
| Electrical |  Light pole |  Pillar |
| Communications |  Pit | |
| Water main |  Hydrant |  Stop Valve |
| Sewer line |  Maintenance Shaft/Chamber |  Man Hole |
| Footpath |  | |

| | |
|----------------|---|
| Filled area |  |
| Denied access |  |
| Retaining wall |  |
| Easement |  |
| Contour |  100.5 |
| Surface level |  95.3 |

Building And Design Information

| | |
|--------------------|---|
| Lot Classification | * |
| Acoustic | * |
| Salinity | * |
| Agressivity | * |
| BAL Rating | * |

| | | |
|---------|---|---|
| | DESIGN | AS BUILT |
| Fill |  |  |
| Contour |  |  |

* Information not available at time of publication
NOTE: SERVICES AND RESTRICTIONS SHOWN ON THIS LEGEND MAY NOT BE APPLICABLE TO THIS LOT
DRAWING REFERENCE: 10202T41(DA2S2)-LOT 2266
DATE: 21 December 2023

It is acknowledged that the dimensions and areas, as well as location of services and the existence and width of easements are subject to change in accordance with the requirements of any relevant Authority. The particulars of this brochure are supplied for information only representing the facts at the time of publication and may change. The particulars shall not be taken as a representation in any respect on the part of the Vendor or its Agent. Authorities should be consulted in relation to any limitations or requirements as building restrictions may apply.