















**LEGEND**

|                |   |  |
|----------------|---|--|
| Drainage       |  Pit                       |  Pit/Lintel |
| Electrical     |  Light pole                |  Pillar     |
| Communications |  Pit                       |  |
| Water main     |  Hydrant                   |  Stop Valve |
| Sewer line     |  Maintenance Shaft/Chamber |  Man Hole   |
| Footpath       |                            |  |

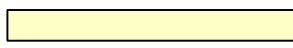
|                |   |
|----------------|---|
| Filled area    |        |
| Denied access  |        |
| Retaining wall |        |
| Easement       |        |
| Contour        |  100.5 |
| Surface level  |  95.3  |

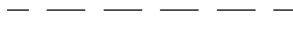
**Building And Design Information**

|                    |   |
|--------------------|---|
| Lot Classification | * |
| Acoustic           | * |
| Salinity           | * |
| Agressivity        | * |
| BAL Rating         | * |

|         |   |   |
|---------|---|---|
|         | DESIGN  | AS BUILT  |
| Fill    |  |  |
| Contour |  |  |

\* Information not available at time of publication  
NOTE: SERVICES AND RESTRICTIONS SHOWN ON THIS LEGEND MAY NOT BE APPLICABLE TO THIS LOT  
DRAWING REFERENCE: 10202T41(DA2S2)-LOT 2226  
DATE: 21 December 2023