















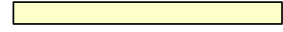

**Legend**

- Drainage  Pit  Pit/Lintel
- Electrical  Lightpole  Pillar
- Communications  Pit
- Water main  Hydrant  Stop Valve
- Sewer line  Maintenance Shaft/Chamber  Rodding Point  Man Hole
- Footpath 

- Filled area 
- Denied access 
- Retaining wall 
- Easement 
- Contour  95.3
- Surface level  x 95.3

**Building And Design Information**

- Fill  [✓] Contour  [✓]
- Lot Classification ----
- Acoustic ----
- Salinity ----
- Aggressivity ----
- BAL Rating ----

\* Information not available at time of publication

It is acknowledged that the dimensions and areas, as well as location of services and the existence and width of easements are subject to change in accordance with the requirements of any relevant Authority. The particulars of this brochure are supplied for information only representing the facts at the time of publication and may change. The particulars shall not be taken as a representation in any respect on the part of the Vendor or its Agent. Authorities should be consulted in relation to any limitations or requirements as building restrictions may apply.