















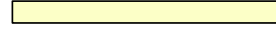

Legend

Drainage	 Pit	 Pit/Lintel
Electrical	 Lightpole	 Pillar
Communications	 Pit	
Water main	 Hydrant	 Stop Valve
Sewer line	 Maintenance Shaft/Chamber	 Rodding Point
Footpath	 Man Hole	

Filled area	
Denied access	
Retaining wall	
Easement	
Contour	 95.3
Surface level	 x 95.3

Building And Design Information

Fill	[✓]	Contour	[✓]
Lot Classification	----	Acoustic	----
Salinity	----	Aggressivity	----
BAL Rating	----		

* Information not available at time of publication

It is acknowledged that the dimensions and areas, as well as location of services and the existence and width of easements are subject to change in accordance with the requirements of any relevant Authority. The particulars of this brochure are supplied for information only representing the facts at the time of publication and may change. The particulars shall not be taken as a representation in any respect on the part of the Vendor or its Agent. Authorities should be consulted in relation to any limitations or requirements as building restrictions may apply.