















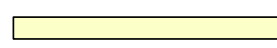

**Legend**

|                |   |   |
|----------------|---|---|
| Drainage       |  Pit                       |  Pit/Lintel    |
| Electrical     |  Lightpole                 |  Pillar        |
| Communications |  Pit                       |   |
| Water main     |  Hydrant                   |  Stop Valve    |
| Sewer line     |  Maintenance Shaft/Chamber |  Rodding Point |
| Footpath       |  Man Hole                  |   |

|                |   |
|----------------|---|
| Filled area    |       |
| Denied access  |       |
| Retaining wall |       |
| Easement       |       |
| Contour        |  95.3 |
| Surface level  |  95.3 |

**Building And Design Information**

|                    |       |              |       |
|--------------------|-------|--------------|-------|
| Fill               | [ ✓ ] | Contour      | [ ✓ ] |
| Lot Classification | ----  | Acoustic     | ----  |
| Salinity           | ----  | Aggressivity | ----  |
| BAL Rating         | ----  |              |       |

\* Information not available at time of publication