

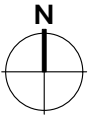

ORAN PARK

Tranche 42, Stage 1  
Lot 2526



Driveway crossovers not constructed by Oran Park. Landowner is to construct the crossover(s) in the nominated location(s) and in accordance with the Estate Design Guidelines. No other crossover locations permitted.

Denotes Nominated Driveway Locations

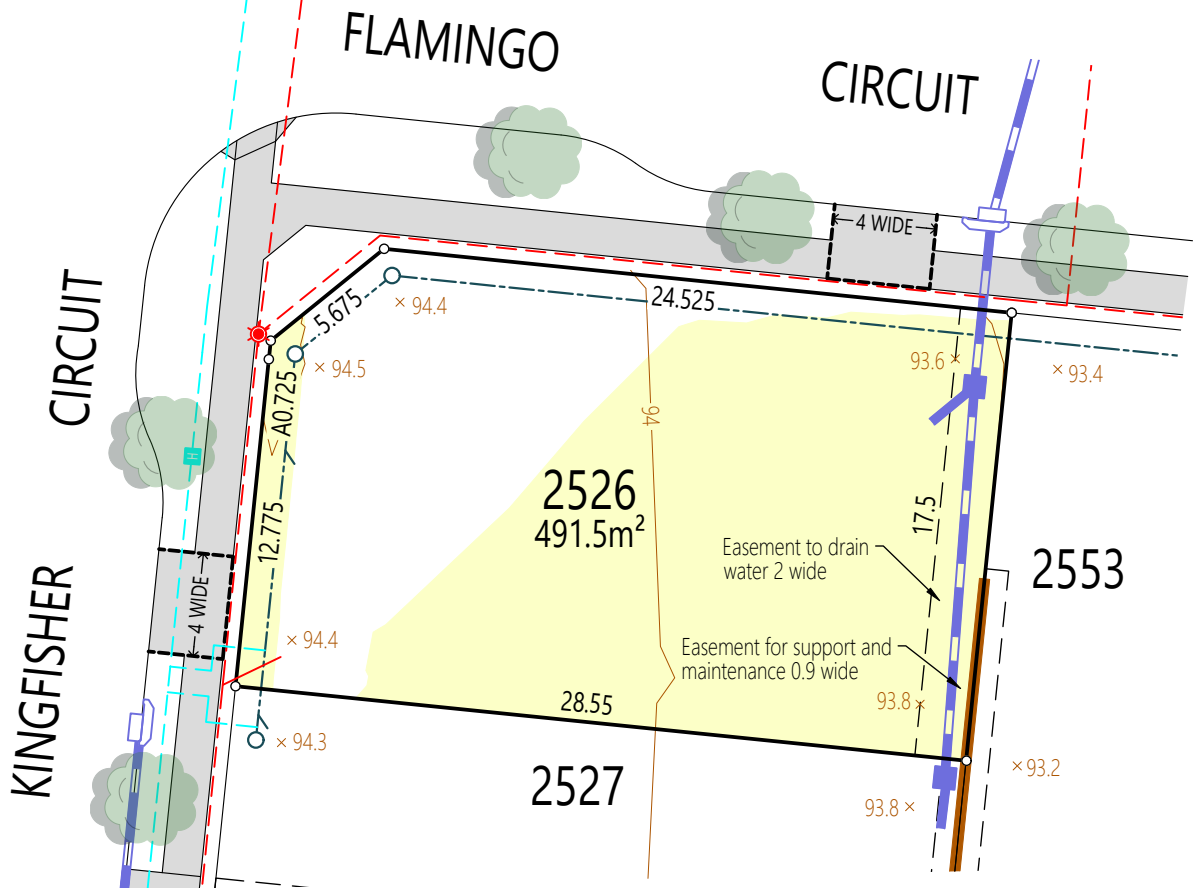

### Legend

Drainage	
Electrical	
Communications *	
Easement	
Water main	
Sewer line	

Footpath	
Filled area	
Denied access	
Retaining wall	
Contour	
Surface level	

### Building And Design Information

Fill	<input checked="" type="checkbox"/>	Contour	<input checked="" type="checkbox"/>
Lot Classification	*		
Acoustic	*		
Salinity	*		
Aggressivity	*		
BAL Rating	*		

\* Information not available at time of publication

It is acknowledged that the dimensions and areas, as well as location of services and the existence and width of easements are subject to change in accordance with the requirements of any relevant Authority. The particulars of this brochure are supplied for information only representing the facts at the time of publication and may change. The particulars shall not be taken as a representation in any respect on the part of the Vendor or its Agent. Authorities should be consulted in relation to any limitations or requirements as building restrictions may apply.





ORAN PARK

Tranche 42, Stage 1  
Lot 2528

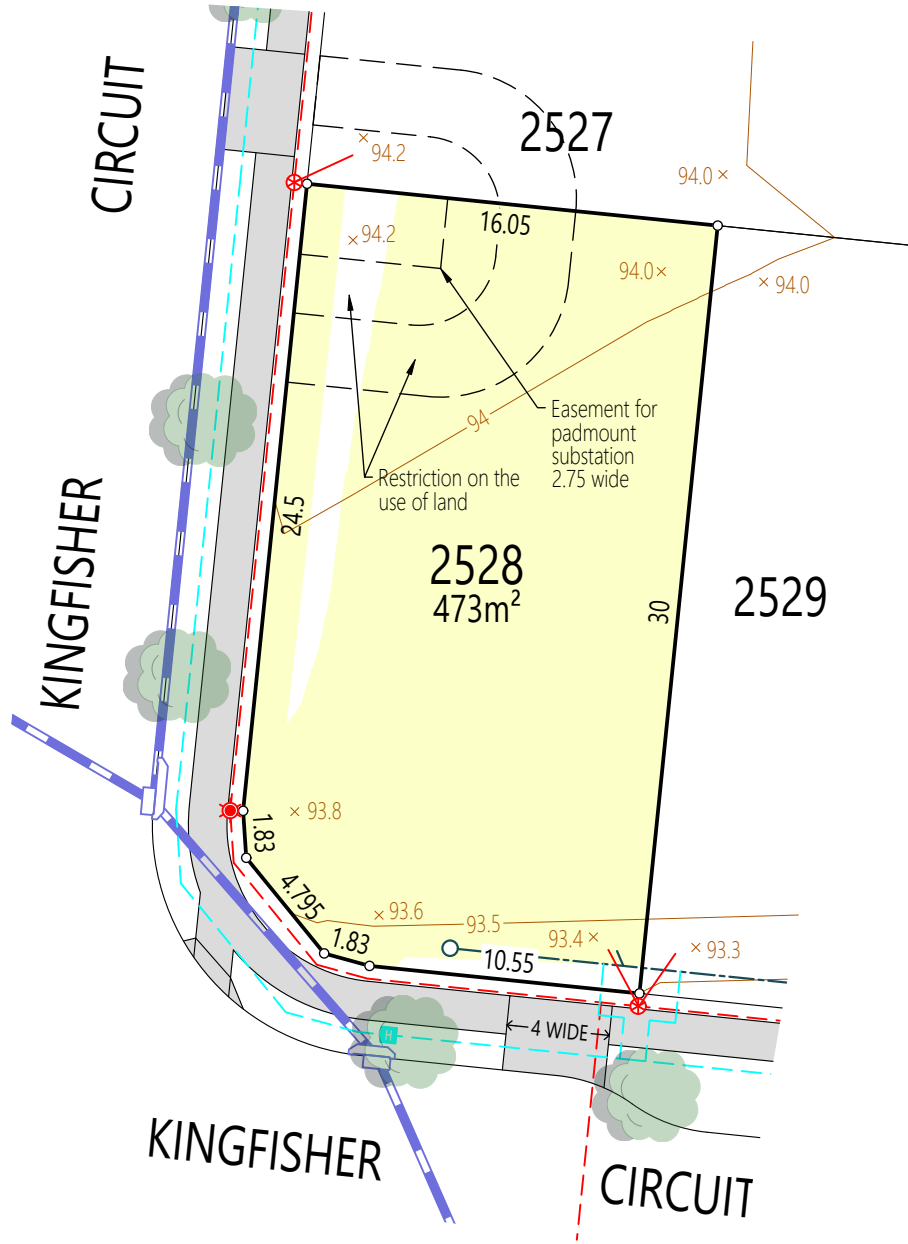
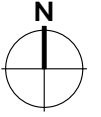

**Legend**

Drainage			
Electrical			
Communications *			
Easement			
Water main			
Sewer line			

Footpath	
Filled area	
Denied access	
Retaining wall	
Contour	
Surface level	$\times 95.3$

**Building And Design Information**

Fill	<input checked="" type="checkbox"/>	Contour	<input checked="" type="checkbox"/>
Lot Classification	*		
Acoustic	*		
Salinity	*		
Aggressivity	*		
BAL Rating	*		







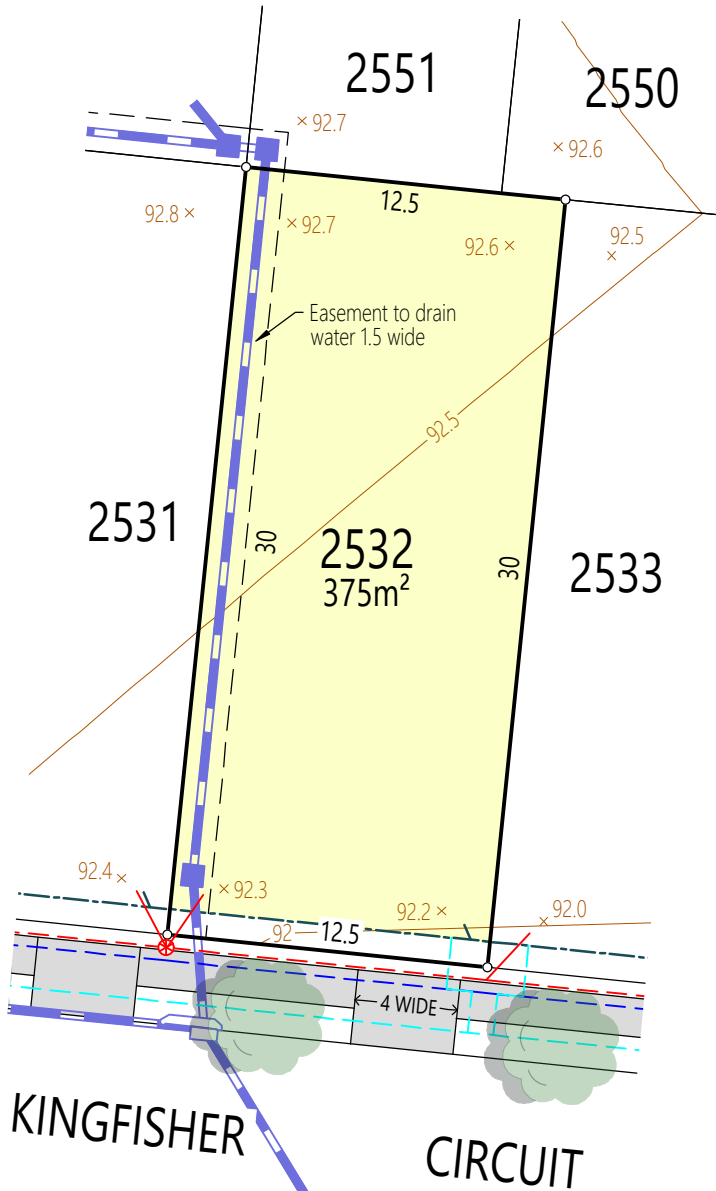
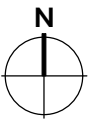





\* Information not available at time of publication





It is acknowledged that the dimensions and areas, as well as location of services and the existence and width of easements are subject to change in accordance with the requirements of any relevant Authority. The particulars of this brochure are supplied for information only representing the facts at the time of publication and may change. The particulars shall not be taken as a representation in any respect on the part of the Vendor or its Agent. Authorities should be consulted in relation to any limitations or requirements as building restrictions may apply.



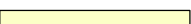

**Legend**

- Drainage   
- Electrical  
- Communications \* 
- Easement 
- Water main  
- Sewer line   

- Footpath 
- Filled area 
- Denied access 
- Retaining wall 
- Contour 
- Surface level 

- Building And Design Information**
- Fill
  - Contour
  - Lot Classification \*
  - Acoustic \*
  - Salinity \*
  - Aggressivity \*
  - BAL Rating \*

\* Information not available at time of publication

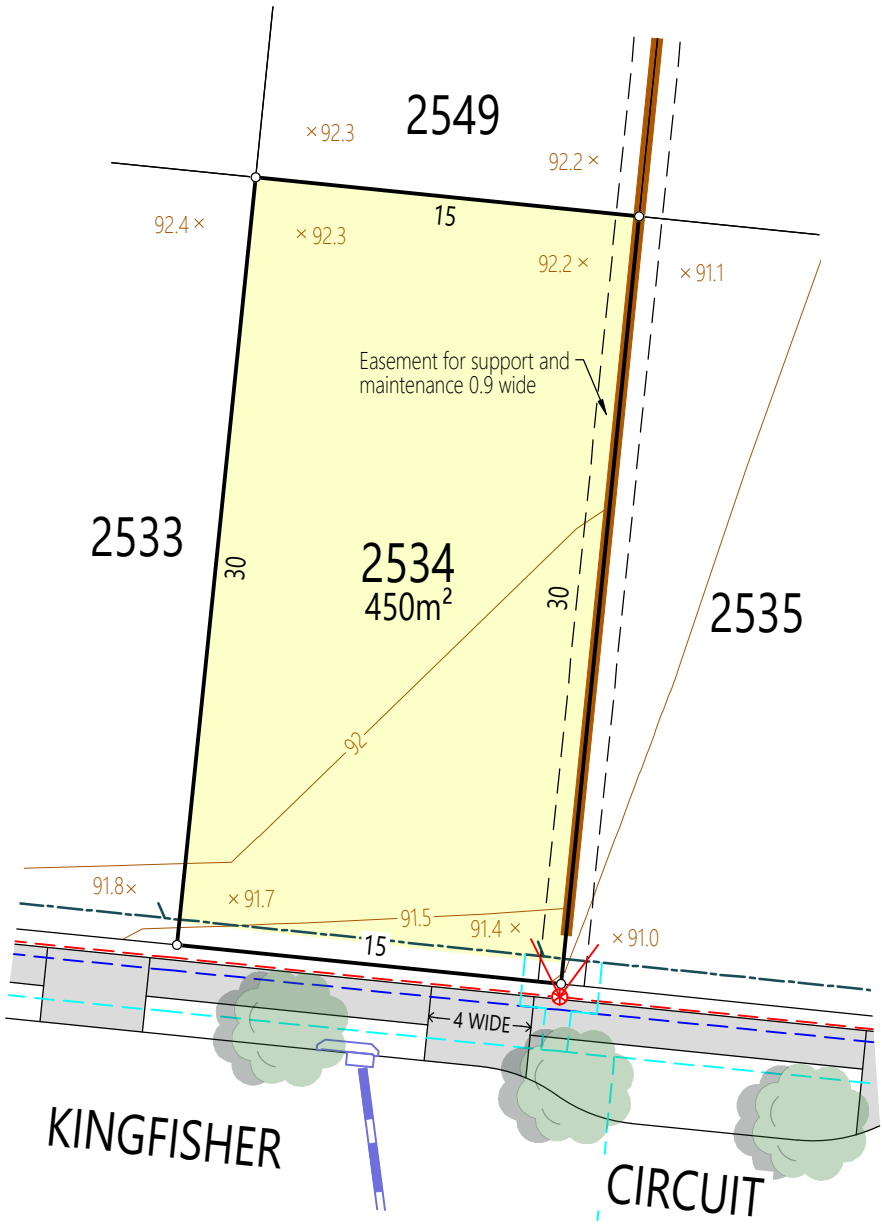
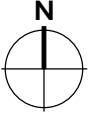

**Legend**

Drainage	
Electrical	
Communications *	
Easement	
Water main	
Sewer line	

Footpath	
Filled area	
Denied access	
Retaining wall	
Contour	
Surface level	$\times 95.3$

**Building And Design Information**

Fill	<input checked="" type="checkbox"/>	Contour	<input checked="" type="checkbox"/>
Lot Classification	*	Acoustic	*
Salinity	*	Aggressivity	*
BAL Rating	*		

\* Information not available at time of publication

It is acknowledged that the dimensions and areas, as well as location of services and the existence and width of easements are subject to change in accordance with the requirements of any relevant Authority. The particulars of this brochure are supplied for information only representing the facts at the time of publication and may change. The particulars shall not be taken as a representation in any respect on the part of the Vendor or its Agent. Authorities should be consulted in relation to any limitations or requirements as building restrictions may apply.



ORAN PARK

Tranche 42, Stage 1  
Lot 2535

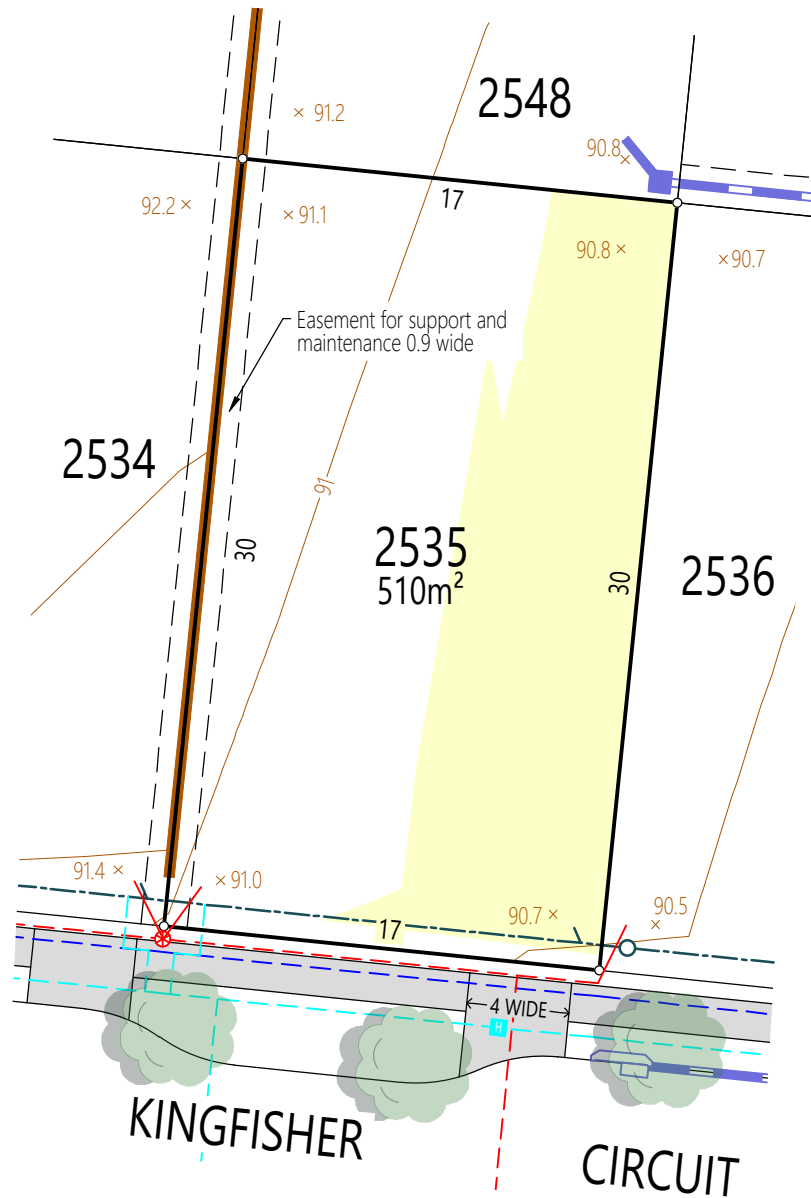
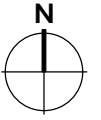

### Legend

Drainage	
Electrical	
Communications *	
Easement	
Water main	
Sewer line	

Footpath	
Filled area	
Denied access	
Retaining wall	
Contour	
Surface level	$\times 95.3$

### Building And Design Information

Fill	<input checked="" type="checkbox"/>	Contour	<input checked="" type="checkbox"/>
Lot Classification	*		
Acoustic	*		
Salinity	*		
Aggressivity	*		
BAL Rating	*		

\* Information not available at time of publication

It is acknowledged that the dimensions and areas, as well as location of services and the existence and width of easements are subject to change in accordance with the requirements of any relevant Authority. The particulars of this brochure are supplied for information only representing the facts at the time of publication and may change. The particulars shall not be taken as a representation in any respect on the part of the Vendor or its Agent. Authorities should be consulted in relation to any limitations or requirements as building restrictions may apply.





ORAN PARK

Tranche 42, Stage 1  
Lot 2540

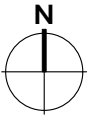

Driveway crossovers not constructed by Oran Park. Landowner is to construct the crossover(s) in the nominated location(s) and in accordance with the Estate Design Guidelines. No other crossover locations permitted.

Denotes Nominated Driveway Locations

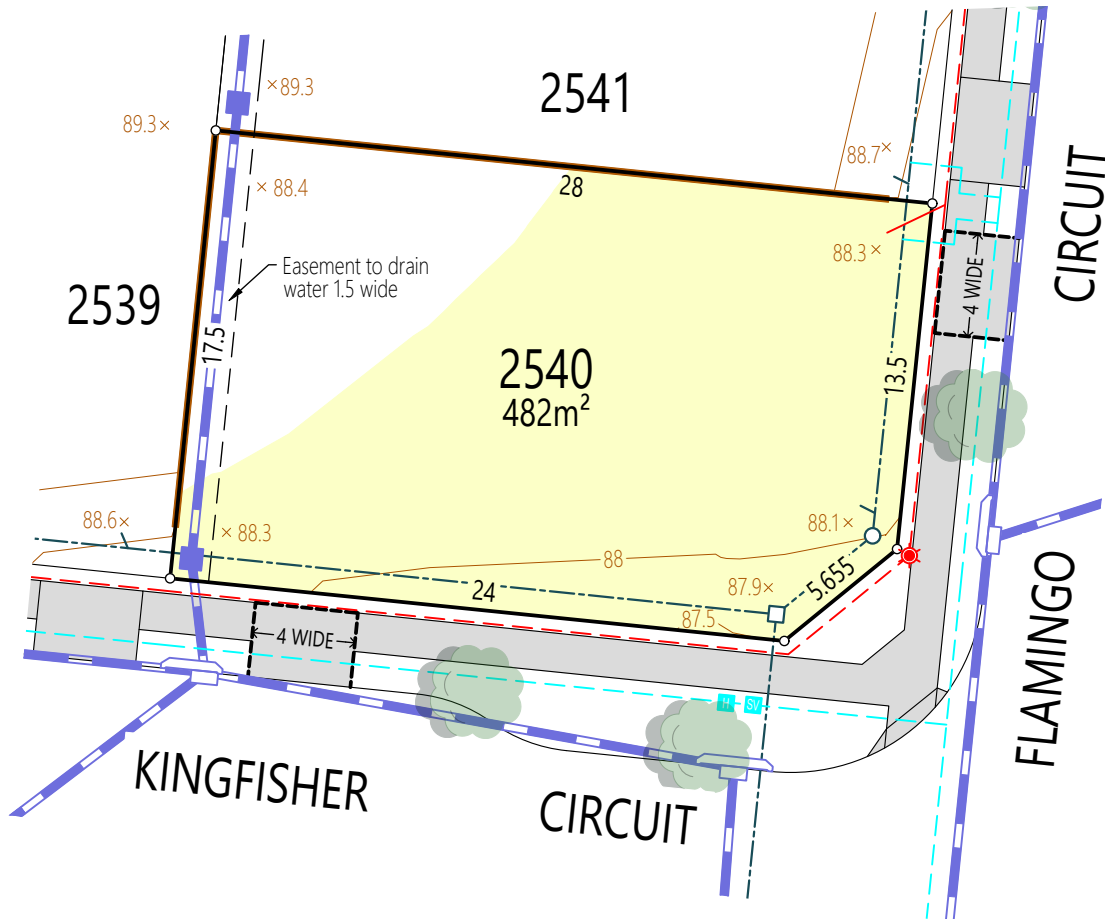

**Legend**

Drainage	
Electrical	
Communications *	
Easement	
Water main	
Sewer line	

Footpath	
Filled area	
Denied access	
Retaining wall	
Contour	
Surface level	$\times 95.3$

**Building And Design Information**

Fill	<input checked="" type="checkbox"/>	Contour	<input checked="" type="checkbox"/>
Lot Classification	*	Acoustic	*
Salinity	*	Aggressivity	*
BAL Rating	*		





\* Information not available at time of publication

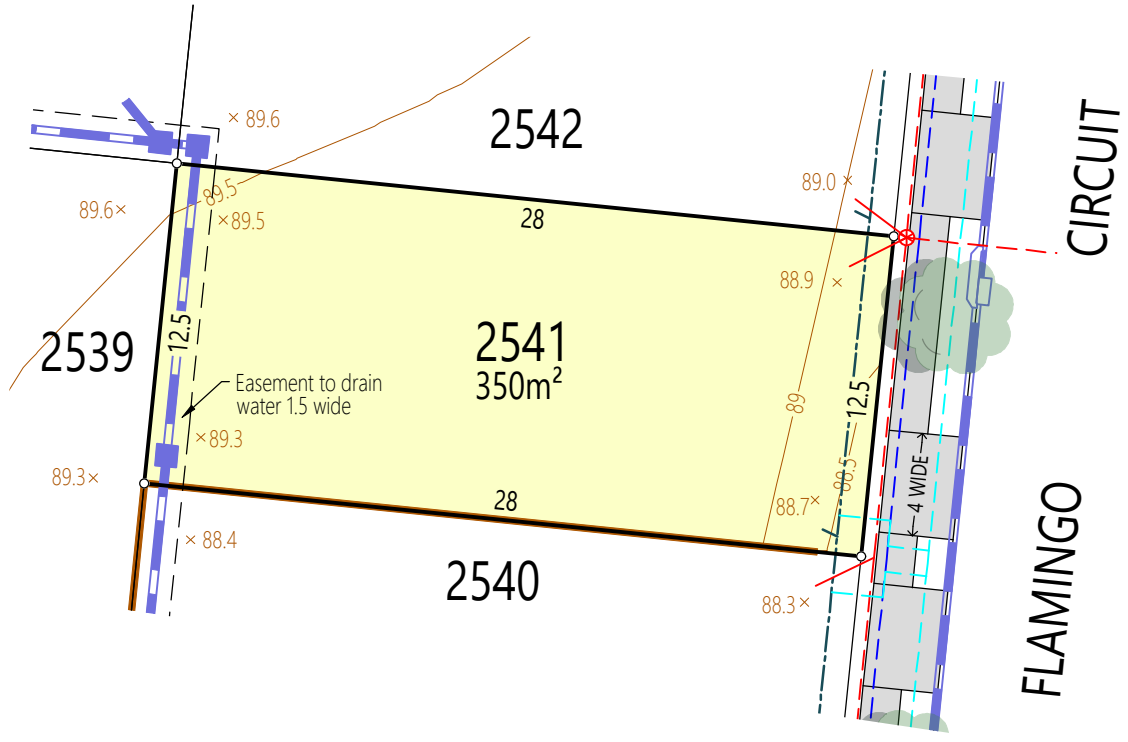
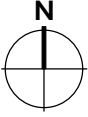



It is acknowledged that the dimensions and areas, as well as location of services and the existence and width of easements are subject to change in accordance with the requirements of any relevant Authority. The particulars of this brochure are supplied for information only representing the facts at the time of publication and may change. The particulars shall not be taken as a representation in any respect on the part of the Vendor or its Agent. Authorities should be consulted in relation to any limitations or requirements as building restrictions may apply.

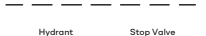

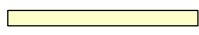

**Legend**

- Drainage 
- Electrical 
- Communications \* 
- Easement 
- Water main 
- Sewer line 

- Footpath 
- Filled area 
- Denied access 
- Retaining wall 
- Contour  95.3
- Surface level  ×95.3





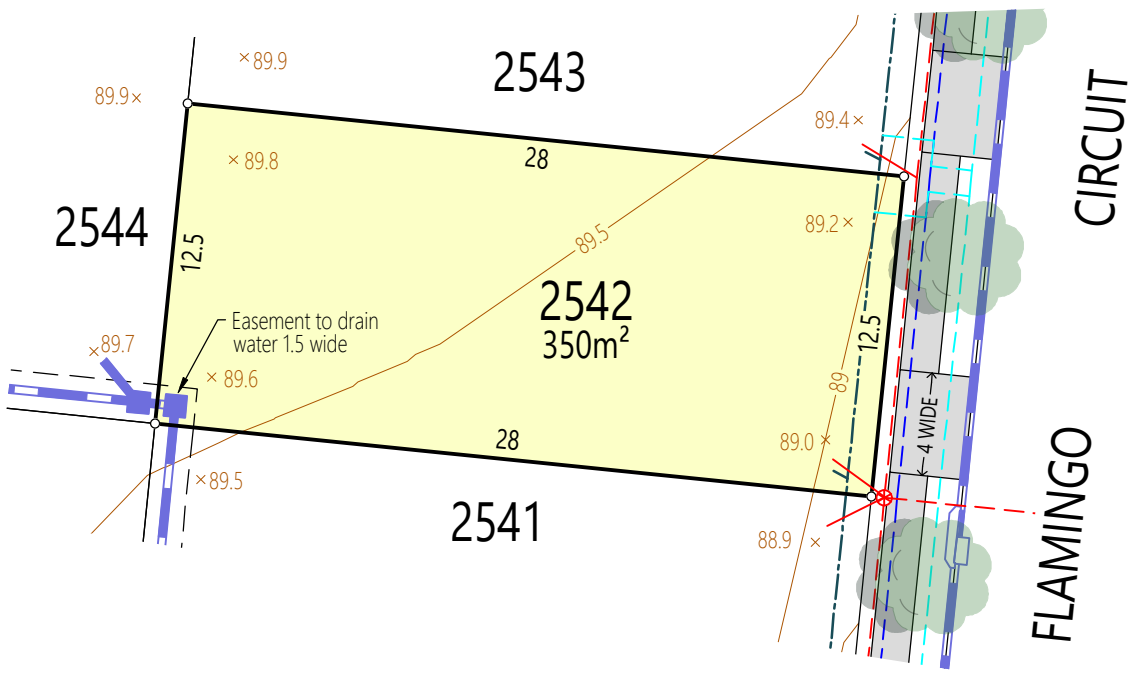
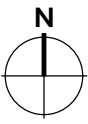

- Building And Design Information**
- Fill
  - Contour
  - Lot Classification \*
  - Acoustic \*
  - Salinity \*
  - Aggressivity \*
  - BAL Rating \*





\* Information not available at time of publication

It is acknowledged that the dimensions and areas, as well as location of services and the existence and width of easements are subject to change in accordance with the requirements of any relevant Authority. The particulars of this brochure are supplied for information only representing the facts at the time of publication and may change. The particulars shall not be taken as a representation in any respect on the part of the Vendor or its Agent. Authorities should be consulted in relation to any limitations or requirements as building restrictions may apply.

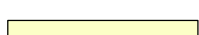

**Legend**

Drainage	
Electrical	
Communications *	
Easement	
Water main	
Sewer line	

Footpath	
Filled area	
Denied access	
Retaining wall	
Contour	
Surface level	

**Building And Design Information**

Fill	<input checked="" type="checkbox"/>	Contour	<input checked="" type="checkbox"/>
Lot Classification	*	Acoustic	*
Salinity	*	Aggressivity	*
BAL Rating	*		

\* Information not available at time of publication

It is acknowledged that the dimensions and areas, as well as location of services and the existence and width of easements are subject to change in accordance with the requirements of any relevant Authority. The particulars of this brochure are supplied for information only representing the facts at the time of publication and may change. The particulars shall not be taken as a representation in any respect on the part of the Vendor or its Agent. Authorities should be consulted in relation to any limitations or requirements as building restrictions may apply.



ORAN PARK

Tranche 42, Stage 1  
Lot 2543

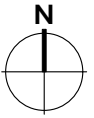

Driveway crossovers not constructed by Oran Park. Landowner is to construct the crossover(s) in the nominated location(s) and in accordance with the Estate Design Guidelines. No other crossover locations permitted.

Denotes Nominated Driveway Locations

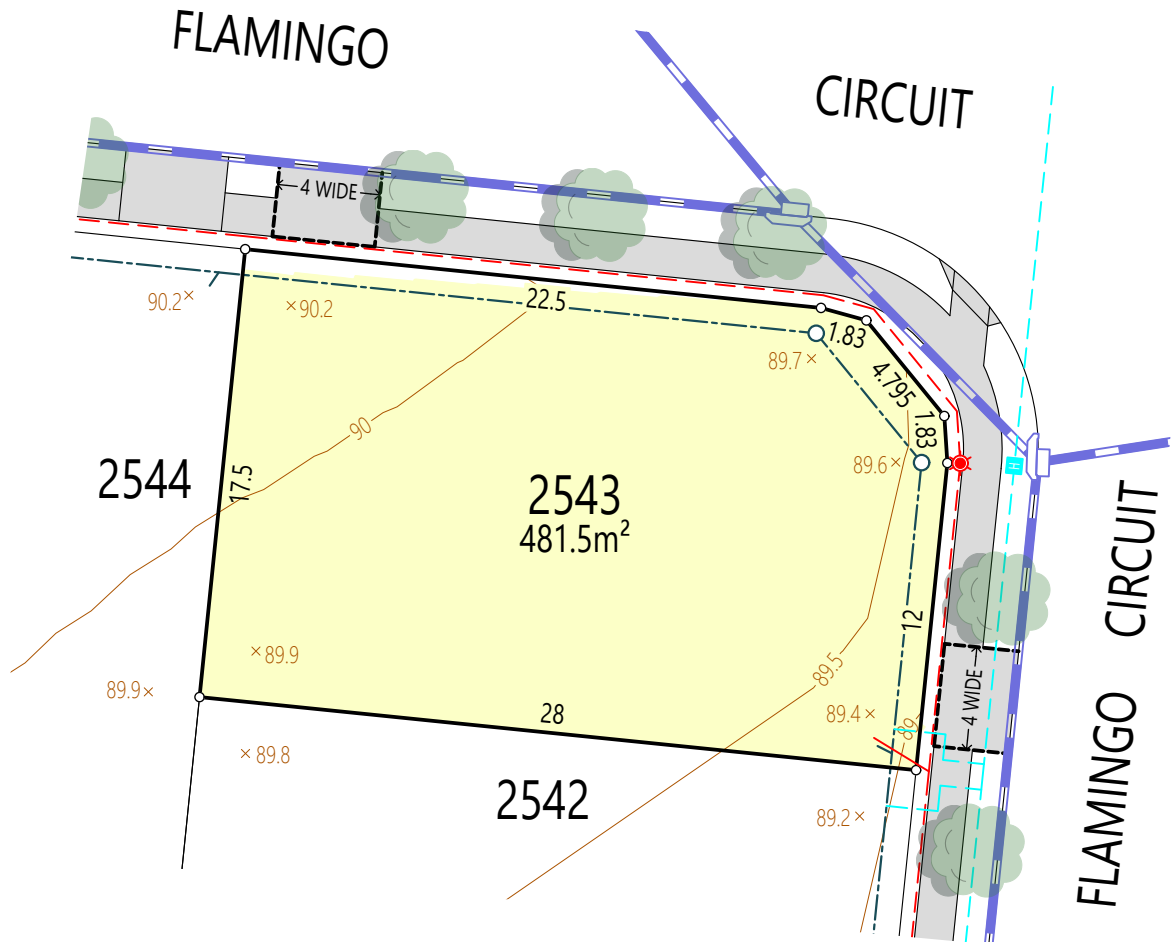

Legend

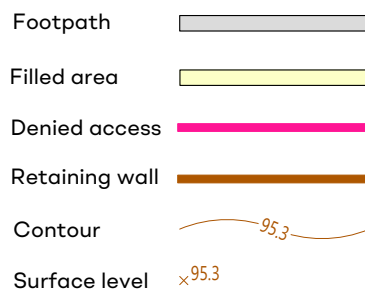
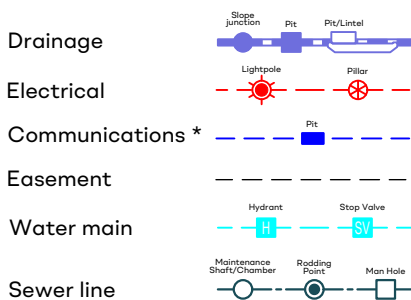

Building And Design Information

Fill	<input checked="" type="checkbox"/>	Contour	<input checked="" type="checkbox"/>
Lot Classification	*		
Acoustic	*		
Salinity	*		
Aggressivity	*		
BAL Rating	*		

\* Information not available at time of publication

It is acknowledged that the dimensions and areas, as well as location of services and the existence and width of easements are subject to change in accordance with the requirements of any relevant Authority. The particulars of this brochure are supplied for information only representing the facts at the time of publication and may change. The particulars shall not be taken as a representation in any respect on the part of the Vendor or its Agent. Authorities should be consulted in relation to any limitations or requirements as building restrictions may apply.





ORAN PARK

Tranche 42, Stage 1  
Lot 2548

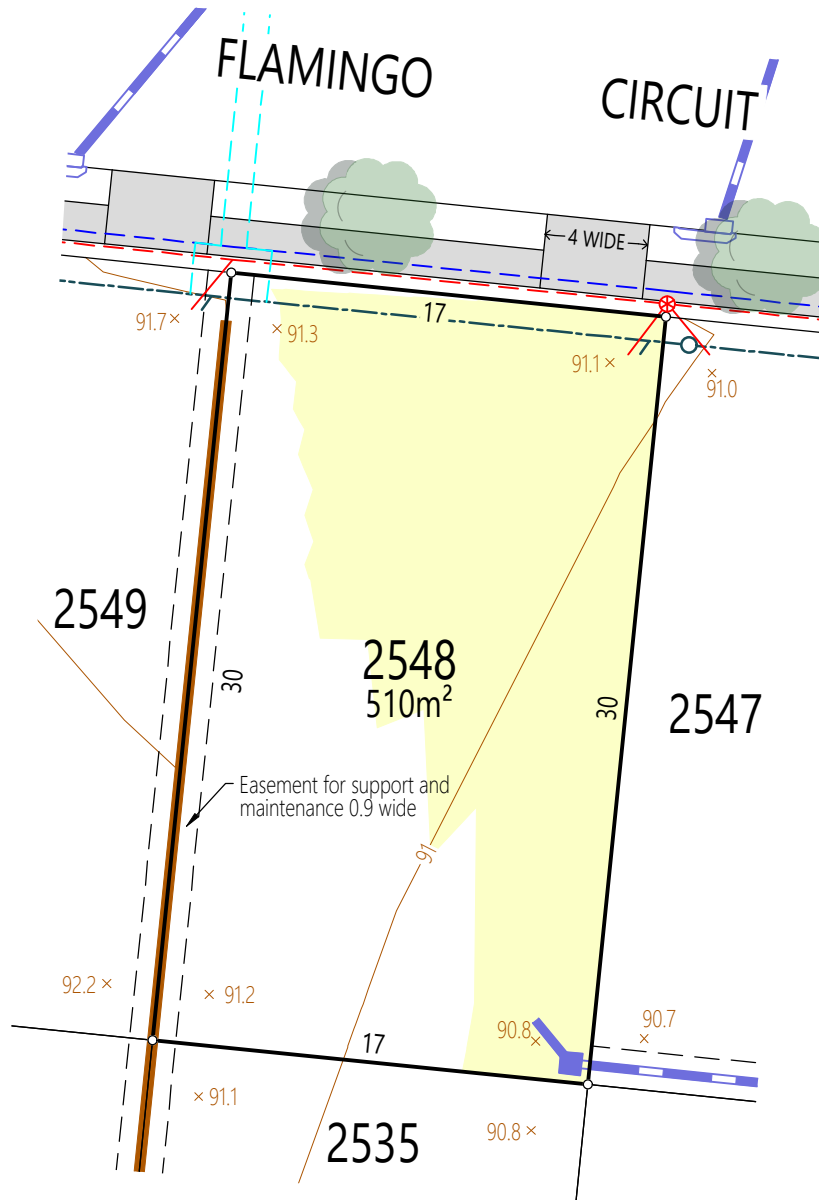
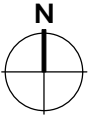

### Legend

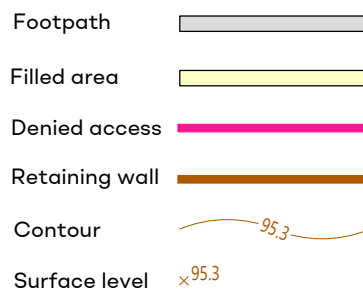
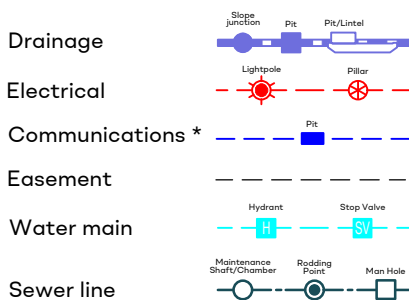

### Building And Design Information

Fill	<input checked="" type="checkbox"/>	Contour	<input checked="" type="checkbox"/>
Lot Classification	*		
Acoustic	*		
Salinity	*		
Aggressivity	*		
BAL Rating	*		

\* Information not available at time of publication

It is acknowledged that the dimensions and areas, as well as location of services and the existence and width of easements are subject to change in accordance with the requirements of any relevant Authority. The particulars of this brochure are supplied for information only representing the facts at the time of publication and may change. The particulars shall not be taken as a representation in any respect on the part of the Vendor or its Agent. Authorities should be consulted in relation to any limitations or requirements as building restrictions may apply.



