

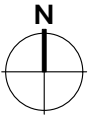



ORAN PARK

Tranche 42, Stage 1 Lot 2526







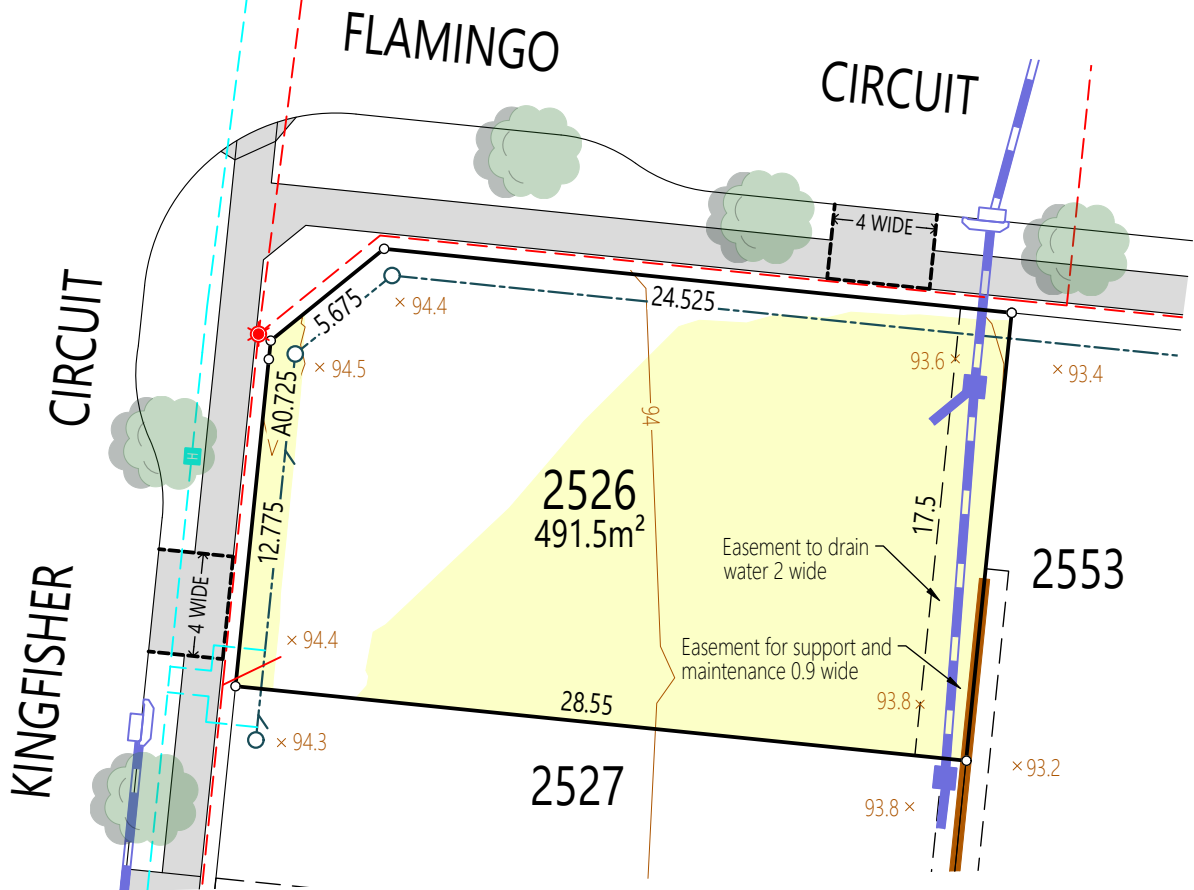











Driveway crossovers not constructed by Oran Park. Landowner is to construct the crossover(s) in the nominated location(s) and in accordance with the Estate Design Guidelines. No other crossover locations permitted.

 Denotes Nominated Driveway Locations

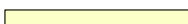

Legend

Drainage	  
Electrical	 
Communications *	
Easement	
Water main	 
Sewer line	  

Footpath	
Filled area	
Denied access	
Retaining wall	
Contour	
Surface level	

Building And Design Information

Fill	<input checked="" type="checkbox"/>	Contour	<input checked="" type="checkbox"/>
Lot Classification	*		
Acoustic	*		
Salinity	*		
Aggressivity	*		
BAL Rating	*		

* Information not available at time of publication

It is acknowledged that the dimensions and areas, as well as location of services and the existence and width of easements are subject to change in accordance with the requirements of any relevant Authority. The particulars of this brochure are supplied for information only representing the facts at the time of publication and may change. The particulars shall not be taken as a representation in any respect on the part of the Vendor or its Agent. Authorities should be consulted in relation to any limitations or requirements as building restrictions may apply.